

SISÄLTÖ

	Sivu
Tyyppi RH	3
Tyyppi RHR	4
Tyyppi RHP	5
Tyyppi RH-PU	6
Tyyppi TC	7
Tyyppi TCP	8
Tyyppi TCR	9
Tyyppi TC-PU	10
Tyyppi TO, kaareva	11
Tyyppi TO, pyöreä	12
Tyyppi TA	13
Tyyppi ET	14
Tyyppi ET-PU	15
Tyyppi ETR	16
Tyyppi DP	17
Tyyppi TF	18

TYYPPI RH

RH-automaattikiristin pitää ketjun kireyden vakiona ja ketjun välyksen muuttumattomana ilman erillisiä säätöjä.

- Kulmakiristys yli 30° molempiin suuntiin.
- Ei muoviosia, voidaan käyttää yli +65°C lämpötilassa.
- Sisältää erittäin joustavan, esijännitetyn joustoelementin, joka pitää kiristyksen mahdollisimman tasaisena.
- Helppo asentaa: kiinnitetään koneeseen ruuvilla joko sisä- tai ulkopuolelta.

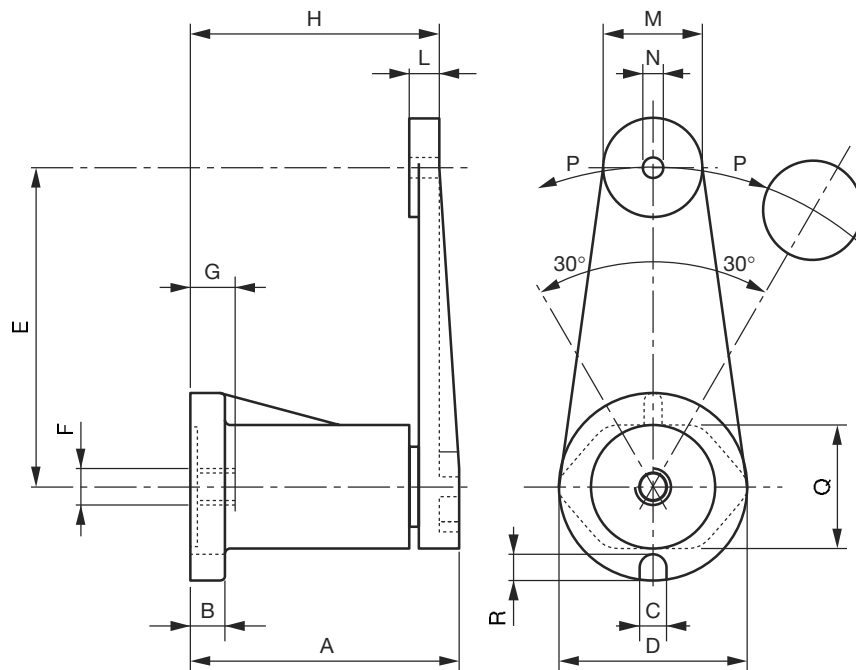

Tyyppi	P [N]	A±1	B	C	D	E	F	G	H±1	L	M	N	Q	R
RH 111	0...100	55	6	8,0	35	80	M6	8,5	51	8	22	5	22	5
RH 155	0...150	69	8	8,5	45	100	M8	10,5	64	8	28	5	30	6
RH 188	0...300	83	10,5	8,5	58	100	M10	13	78	10	32	6,5	37	8
RH 277	0...900	114	15	10,5	78	130	M12	17	107	12	50	8,5	53	10
RH 388	0...1400	140	15	12,5	95	175	M16	20	140	10	60	20,5	70	12
RH 455	0...2300	200	18	12,5	115	225	M20	25	200	12	70	20,5	82	12

TYYPPI RHR

Sisältää laakeroidun ketjupyörän.

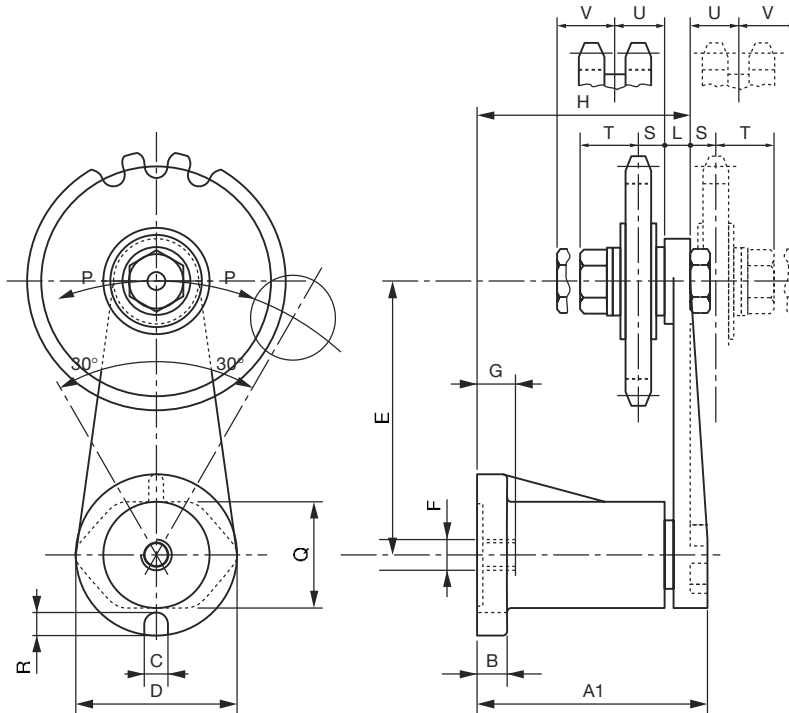

Tyyppi	Ketjulle	P [N]	A±1	B	C	D	E	F	G	H±1	L	Q	R	S	T	U	V	Z
RHR 111	3/8" x 7/32"	0...100	58	6	8,0	35	80	M6	8,5	51	8	22	5	9,2	19,7	9,7	16,7	21
RHR 155	3/8" x 7/32"	0...150	71	8	8,5	45	100	M8	10,5	64	8	30	6	9,2	19,7	9,7	16,7	21
RHP 155	1/2" x 5/16"	0...150	71	8	8,5	45	100	M8	10,5	64	8	30	6	9,2	19,7	12,5	19,5	16
RHR 188	1/2" x 5/16"	0...300	84	10,5	8,5	58	100	M10	13	78	10	37	8	9,2	19,7	12,5	19,5	16
RHR 188	5/8" x 3/8"	0...300	85	10,5	8,5	58	100	M10	13	78	10	37	8	9,2	19,7	15,3	23,3	17
RHR 277	3/4" x 7/16"	0...900	114	15	10,5	78	130	M12	17	107	12	53	10	9,2	19,7	17,7	25,7	15
RHR 277	1" x 17 mm	0...900	114	15	10,5	78	130	M12	17	107	12	53	10	8,9	19,4	26,4	34,4	12
RHR 388	1" x 17 mm	0...1400	149	15	12,5	95	175	M16	20	140	10	70	12	8,9	24,9	26,9	39,9	12
RHR 455	1" 1/4 x 3/4"	0...2300	209	18	12,5	115	225	M20	25	200	12	82	12	105	26,5	30,3	43,3	13

TYYPPI RHP

Kirstin muovielementillä, jolla on pieni liukukitkerroin.

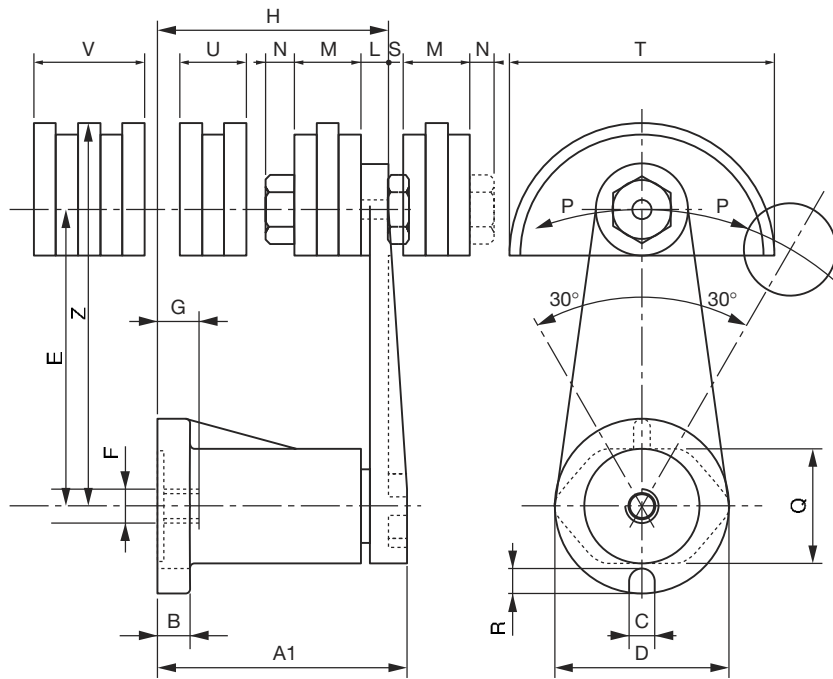

Tyyppi	Ketjulle	P [N]	A±1	B	C	D	E	F	G	H±1	L	M	N	Q	R	S	T	U	V	Z
RHP 111	3/8" x 7/32"	0...100	57	6	8,0	35	80	M6	8,5	51	8	20	7	22	5	4	70	20	25	102
RHP 155	3/8" x 7/32"	0...150	70	8	8,5	45	100	M8	10,5	64	8	20	7	30	6	4	70	20	25	122
RHP 155	1/2" x 5/16"	0...150	70	8	8,5	45	100	M8	10,5	64	8	20	7	30	6	4	70	20	35	122
RHP 188	1/2" x 5/16"	0...300	84	10,5	8,5	58	100	M10	13	78	10	20	7	37	8	4	70	20	35	122
RHP 188	5/8" x 3/8"	0...300	85	10,5	8,5	58	100	M10	13	78	10	22	8	37	8	5	90	25	41,5	129
RHP 277	3/4" x 7/16"	0...900	114	15	10,5	78	130	M12	17	107	12	22	8	53	10	5	90	30	49	159
RHP 277	1" x 17 mm	0...900	114	15	10,5	78	130	M12	17	107	12	25	8	53	10	5	110	45	78	165
RHP 388	1" 1/4 x 3/4"	0...1400	149	15	12,5	95	175	M16	20	140	10	25	13	70	12		110	54	90	210
RHP 455	1" 1/2 x 1"	0...2300	209	18	12,5	115	225	M20	25	200	12	25	13	82	12		110	71	119	260

TYYPPI RH-PU

Sisältää laakeroidun rullan.

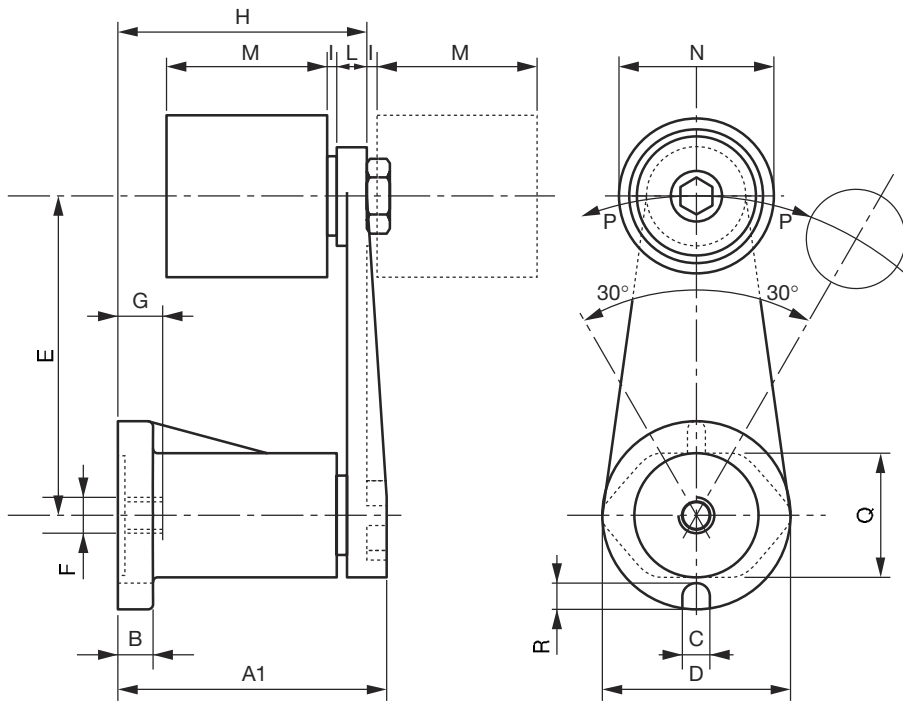

Tyyppi	P [N]	A±1	B	C	D	E	F	G	H±1	I	L	M	N	Q	R
RHPU 111	0...100	57	6	8,0	35	80	M6	8,5	51	2	8	35	30	22	5
RHPU 155	0...150	71	8	8,5	45	100	M8	10,5	64	2,5	8	50	50	30	6
RHPU 188	0...300	85	10,5	8,5	58	100	M10	13	78	2,5	10	50	50	37	8
RHPU 277	0...900	114	15	10,5	78	130	M12	17	107	2,5	12	50	50	53	10
RHPU 388	0...1400	149	15	12,5	95	175	M16	20	140	3	10	70	70	70	12
RHPU 455	0...2300	209	18	12,5	115	225	M20	25	200	3	12	70	70	82	12

TYYPPI TC

TC-automaattikiristin pitää ketjun kireyden vakiona ja ketjun välyksen muuttumattomana.

- Kulmakiristys yli 45° molempiin suuntiin.
- Ei muoviosia, voidaan käyttää yli +100°C lämpötilassa (sarja TCP +65°C).
- Sisältää erittäin joustavan jousen, joka pitää kiristykseen mahdollisimman tasaisena.
- Helppo asentaa: kiinnitetään koneeseen ruuvilla joko sisä- tai ulkopuolelta.

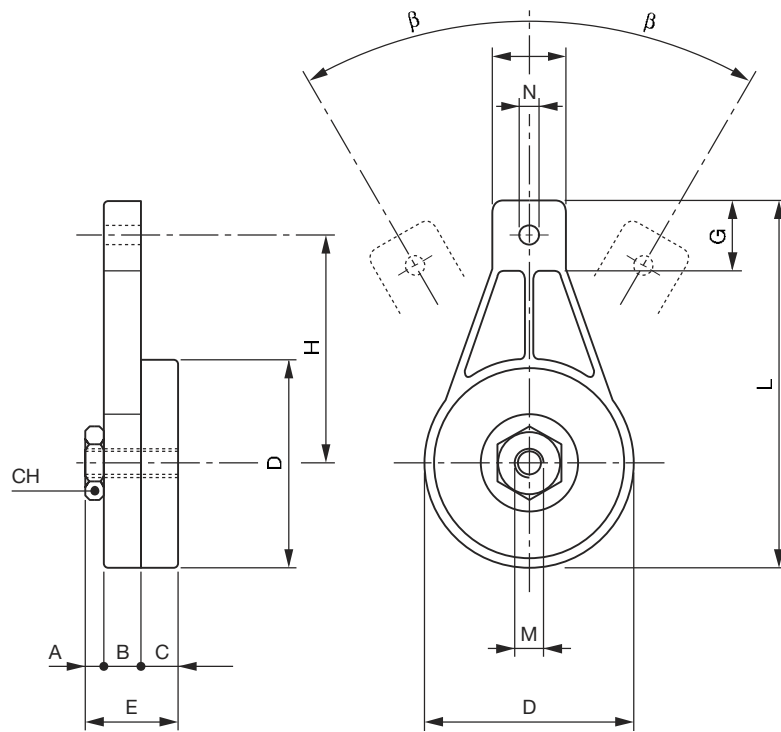

TYYPPI	P [N]		A	B	C	CH	D	E	F	G	H	L	M	N	b
	min.	maks.													
*TC-05	80	160	5	15	15	24	63	35	23	23	75,5	119	M10	6,5	45°
TC-1	120	240	5	15,5	15,5	24	69	36	30	25	86,5	134	M10	8,5	45°
TC-2	240	380	7	18	18	27	90	43	34	30	100	169	M12	8,5	30°

* Muovirakenne

TYYPPI TCP

Kiristin muovielementillä, jolla on pieni liukukitkakerron.

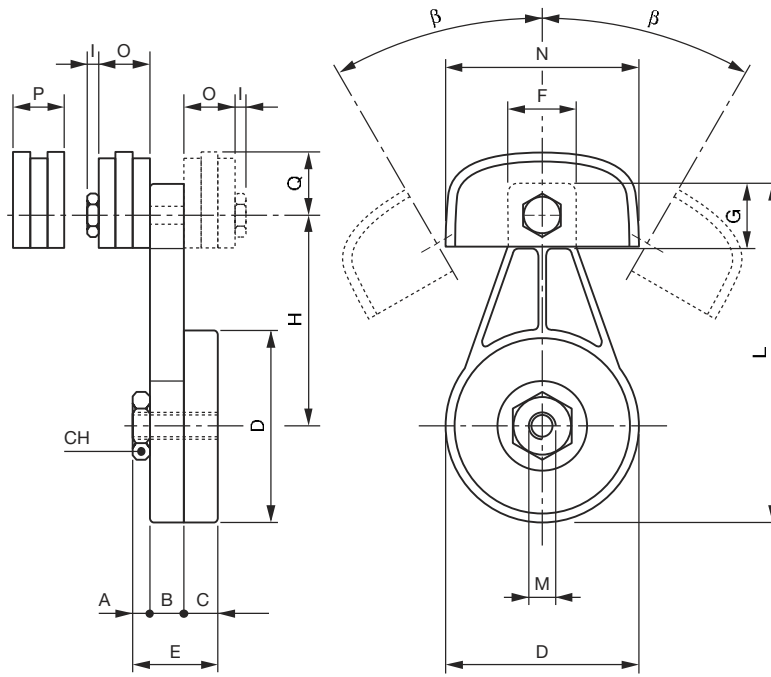

Tyyppi	P [N]		Ketjulle	A	B	C	CH	D	E	F	G	H	I	L	M	N	O	P	Q	b
	min.	maks.																		
*TCP - 05 - 8 x 3	80	160	8 x 3	5	15	15	24	63	35	23	23	75,5	5,5	119	M10	70	20		22	45°
*TCP - 05 - 3/8"	80	160	3/8" x 7/32"	5	15	15	24	63	35	23	23	75,5	5,5	119	M10	70	20		22	45°
TCP - 1 - 3/8"	100	210	3/8" x 7/32"	5	15,5	15,5	24	69	36	30	25	86,5	7	134	M10	70	20	20	22	45°
TCP - 1 - 1/2"	100	210	1/2" x 5/16"	5	15,5	15,5	24	69	36	30	25	86,5	7	134	M10	70	20	20	22	45°
TCP - 1 - 5/8"	120	240	5/8" x 3/8"	5	15,5	15,5	24	69	36	30	25	86,5	7	134	M10	90	22	25	29	45°
TCP - 2 - 5/8"	200	350	5/8" x 3/8"	7	18	18	27	90	43	34	30	100	8	159	M12	90	22	25	29	30°
TCP - 2 - 3/4"	200	350	3/4" x 7/16"	7	18	18	27	90	43	34	30	100	8	159	M12	90	22	30	29	30°
TCP - 2 - 1"	240	380	1" x 17 mm	7	18	18	27	90	43	34	30	100	8	159	M12	110	25	45	35	30°

* Muovirakenne

Tilauseimerkki: Kiristin yksiriviselle ketjulle, jako 1/2" = TCP - 1 - 1/2" A1
 A1 = yksirivinen ketju, A2 = kaksirivinen ketju

TYYPPI TCR

Sisältää laakeroidun ketjupyörän.

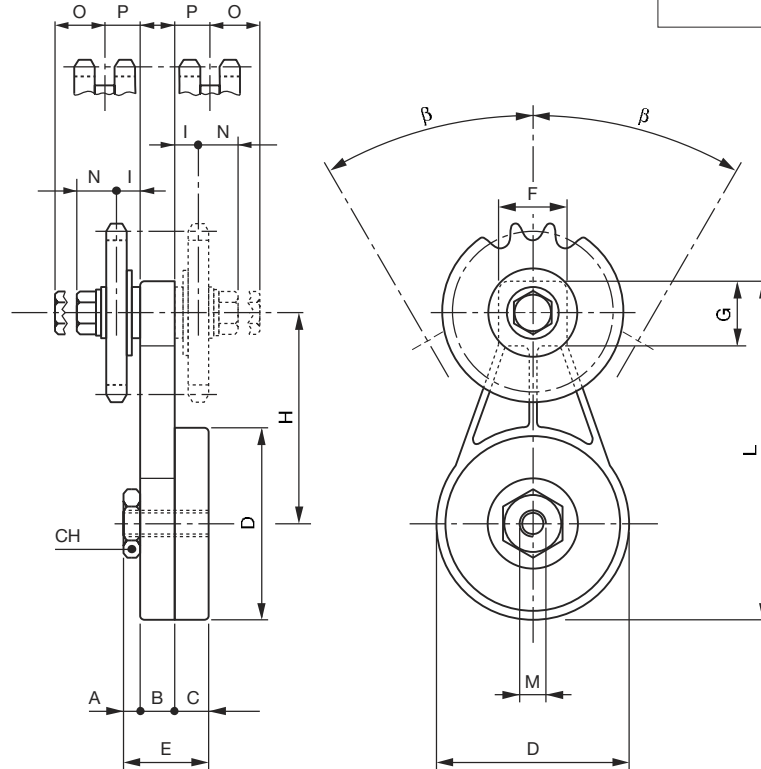

Tyyppi	P [N]		Ketjulle	Z	A	B	C	CH	D	E	F	G	H	I	L	M	N	O	P	b	
	min.	maks.																			
*TCR - 05 - 8 x 3	80	160	8 x 3	22	5	15	15	24	63	35	23	23	7,5	6,0	119	M10	13				45°
*TCR - 05 - 3/8"	80	160	3/8" x 7/32"	21	5	15	15	24	63	35	23	23	75,5	9,2	119	M10	19,7				45°
TCR - 1 - 3/8"	100	210	3/8" x 7/32"	21	5	15,5	15,5	24	69	36	30	25	86,5	9,2	134	M10	19,7	18	11,0		45°
TCR - 1 - 1/2"	100	210	1/2" x 5/16"	16	5	15,5	15,5	24	69	36	30	25	86,5	9,2	134	M10	19,7	16,5	12,5		45°
TCR - 1 - 5/8"	120	240	5/8" x 3/8"	17	5	15,5	15,5	24	69	36	30	25	86,5	9,2	134	M10	19,7	21,8	15,3		45°
TCR - 2 - 5/8"	200	350	5/8" x 3/8"	17	7	18	18	27	90	43	34	30	100	9,2	159	M12	19,7	21,8	15,3		30°
TCR - 2 - 3/4"	200	350	3/4" x 7/16"	15	7	18	18	27	90	43	34	30	100	9,2	159	M12	19,7	19,4	17,7		30°
TCR - 2 - 1"	240	380	1" x 17 mm	12	7	18	18	27	90	43	34	30	100	8,9	159	M12	19,4	23,9	26,4		30°

* Muovirakenne

Tilauseimerkki: Kiristin yksiriviselle ketjulle, jako 1/2" = TCR - 1 - 1/2" A1
A1 = yksirivinen ketju, A2 = kaksirivinen ketju

TYYPPI TC-PU

- Rulla sinkittyä terästä AQ 42 tai kevytmetallia.
- Laakerit kestovoidellut, kaksoistivistein.

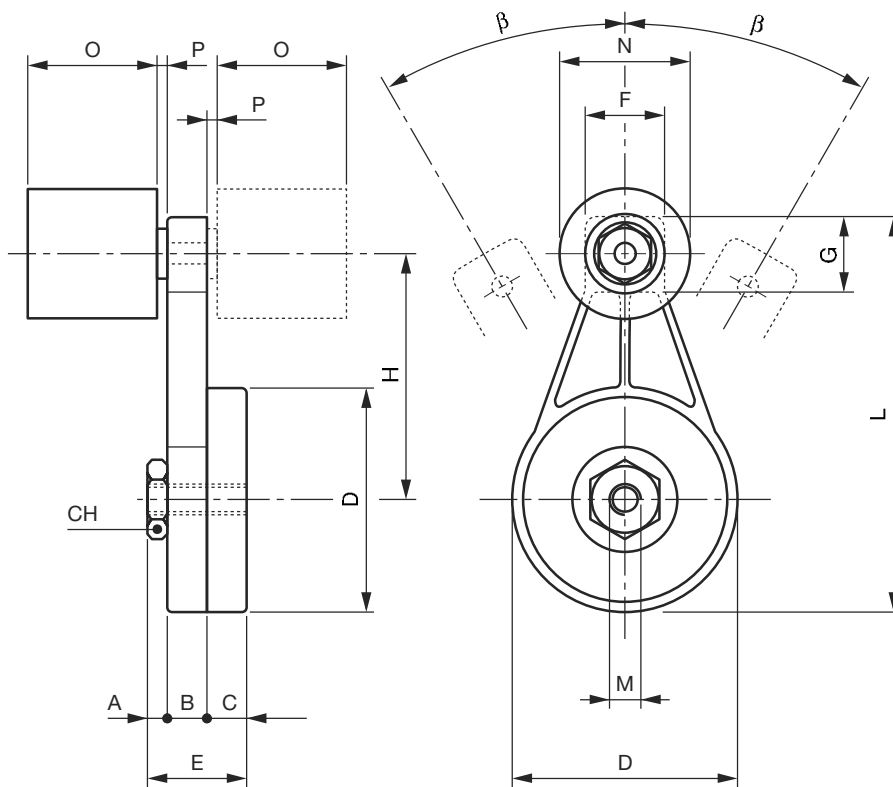

Tyyppi	P [N]		A	B	C	CH	D	E	F	G	H	L	M	N	O	P	b
	min.	maks.															
TC - 1 - PU	120	240	5	15,5	15,5	24	69	36	30	25	86,5	134	M10	50	50	2,5	45°
TC - 2 - PU	240	380	7	18,0	18,0	27	90	43	34	30	100	159	M12	50	50	2,5	30°

TYYPPI TO, KAAREVA

Linearisesti jousella toimiva kiristin kulutusta kestävällä muovielementillä, jolla on pieni liukukitkerroin.

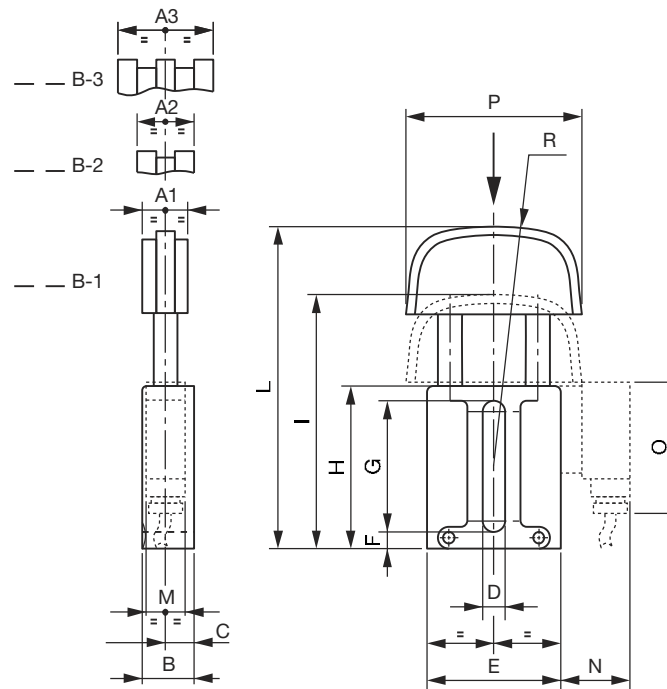

Tyyppi	P [N]		Ketjulle	A1	A2	A3	B	C	D	E	F	G	H	I	L	M	N	O	P	R	
	min.	maks.																			
*TO - 05 - 3/8"	95	190	3/82 x 7/32"	20			23	12,5	9	60	10	53	75	120	149					70	100
*TO - 05 - 1/2"	95	190	1/2" x 5/16"	20			23	12,5	9	60	10	53	75	120	149					70	100
TO - 1 - 3/8"	130	250	3/8" x 7/32"	20	20	25	23	12,5	11	56,2	7	58	74	110	138					70	100
TO - 1 - 1/2"	130	250	1/2" x 5/16"	20	20	35	23	12,5	11	56,2	7	58	74	110	138					70	100
TO - 1 - 5/8"	130	250	5/8" x 3/8"	20	25	41,5	23	12,5	11	56,2	7	58	74	110	138					70	100
TO - 2 - 5/8"	180	420	5/8" x 3/8"	22	25	41,5	28	15,0	12,5	70,5	9	70	87	133	169					90	120
TO - 2 - 3/4"	180	420	3/4" x 7/16"	22	30	49	28	15,0	12,5	70,5	9	70	87	133	169					90	120
TO - 3 - 1"	300	650	1" x 17 mm	25	45	78	33	17,5	14,5	82	9	86	104	160	202	21	35	70	110	140	
TO - 3 - 1" 1/4	300	650	1" 1/4 x 3/4"	25	54	90	33	17,5	14,5	82	9	86	104	160	202	21	35	70	110	140	
TO - 3 - 1" 1/2	300	650	1" 1/2 x 1"	25	71	119	33	17,5	14,5	82	9	86	104	160	202	21	35	70	110	140	

* Muovirakenne

TYYPPI TO, PYÖREÄ

Linearisesti jousella toimiva kiristin kulutusta kestävällä muovielementillä, jolla on pieni liukukittakerroin.

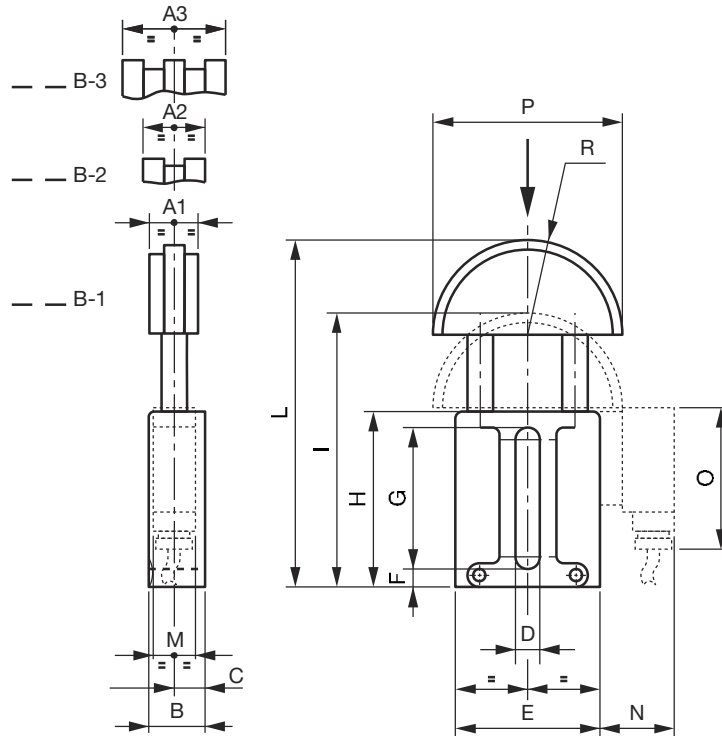
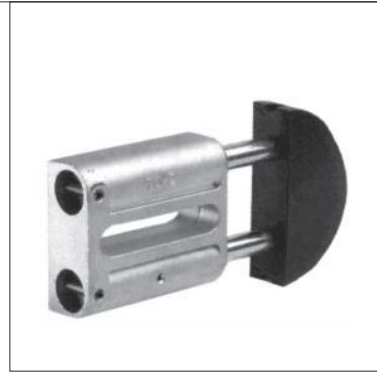

Tyyppi	P [N]		Ketjulle	A1	A2	A3	B	C	D	E	F	G	H	I	L	M	N	O	P	R
	min.	maks.																		
TO - 1 - 3/8"	130	250	3/8" x 7/32"	20	20	25	23	12,5	11,0	56,2	7	58	74	110	138				70	35
TO - 1 - 1/2"	130	250	1/2" x 5/16"	20	20	35	23	12,5	11,0	56,2	7	58	74	110	138				70	35
TO - 1 - 5/8"	130	250	5/8" x 3/8"	20	25	41,5	23	12,5	11,0	56,2	7	58	74	110	138				70	35
TO - 2 - 5/8"	180	420	5/8" x 3/8"	22	25	41,5	28	15,0	12,5	70,5	9	70	87	133	169				90	45
TO - 2 - 3/4"	180	420	3/4" x 7/16"	22	30	49	28	15,0	12,5	70,5	9	70	87	133	169				90	45
TO - 3 - 1"	300	650	1" x 17 mm	25	45	78	33	17,5	14,5	82	9	86	104	160	202	21	35	70	110	55
TO - 3 - 1" 1/4	300	650	1" 1/4 x 3/4"	25	54	90	33	17,5	14,5	82	9	86	104	160	202	21	35	70	110	55
TO - 3 - 1" 1/2	300	650	1" 1/2 x 1"	25	71	119	33	17,5	14,5	82	9	86	104	160	202	21	35	70	110	55

TYYPPI TA

- Kulutusta kestävä muovinen liukuosa, jolla on pieni liukukitkerroin (dynaaminen kitkerroin 0,06 kuivalla teräksellä).
- Lujat, hiotut ohjauspultit terästä.
- Akseleilla itsevoitelevat pronssilaakerit.

Kiristimet soveltuvat ISO-normin mukaisille ketjulle.

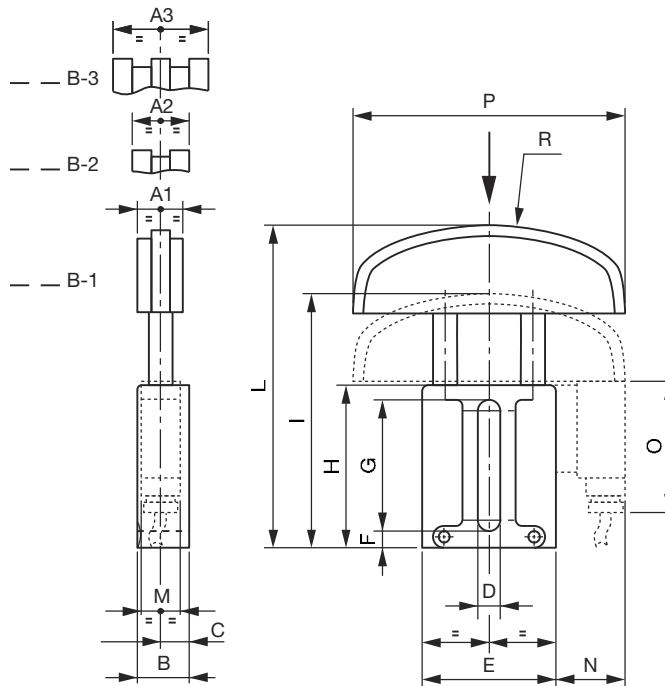

Tyyppi	P [N]		Ketjulle	A1	A2	A3	B	C	D	E	F	G	H	I	L	M	N	O	P	R
	min.	maks.																		
TA - 1 - 3/8"	130	250	3/8" x 7/32"	20	20	25	23	12,5	11,0	56,2	7	58	74	115	143				140	120
TA - 1 - 1/2"	130	250	1/2" x 5/16"	20	20	35	23	12,5	11,0	56,2	7	58	74	115	143				140	120
TA - 2 - 5/8"	180	420	5/8" x 3/8"	22	25	41,5	28	15,0	12,5	70,5	9	70	87	128	164				140	140
TA - 2 - 3/4"	180	420	3/4" x 7/16"	22	30	49	28	15,0	12,5	70,5	9	70	87	128	164				140	140
TA - 3 - 1"	300	650	1" x 17 mm	25	45	78	33	17,5	14,5	82	9	86	104	145	187	21	35	70	140	160
TA - 3 - 1" 1/4	300	650	1" 1/4 x 3/4"	25	54	90	33	17,5	14,5	82	9	86	104	145	187	21	35	70	140	160
TA - 3 - 1" 1/2	300	650	1" 1/2 x 1"	25	71	119	33	17,5	14,5	82	9	86	104	145	187	21	35	70	140	160

Tilauseimerkki: Kiristin kaksiriviselle ketjulle, jako 1/2" = TA - 1 - 1/2" A2

TYYPPI ET

- Lujat, hiotut ohjauspultit terästä.
- Akseleilla itsevoitelevat pronssiilaakerit.

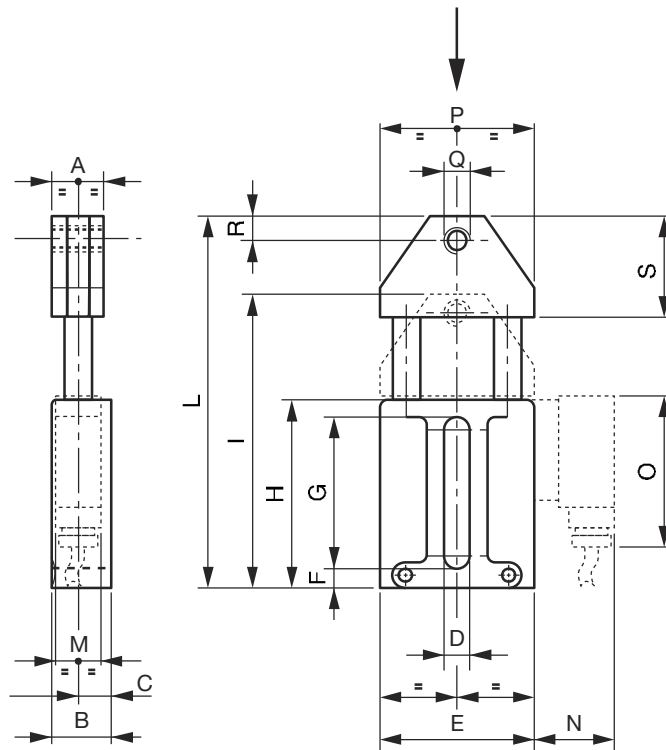

Tyyppi	P [N]		A	B	C	D	E	F	G	H	I	L	M	N	O	P	Q	R	S
	min.	maks.																	
ET 1	130	250	20	23	12,5	11	56,2	7	58	74	109	137				60	M10	10	35
ET 2	180	420	25	28	15,0	12,5	70,5	9	70	87	139	175				70	M12	12	50
ET 3	300	650	30	33	17,5	14,5	82,0	9	86	104	165	207	21	35	70	80	M14	14	60

TYYPPI ET-PU

- Lujat, hiotut ohjauspultit terästä.
- Akseleilla itsevoitelevat pronssilaakerit.
- Sisältää laakeroidun rullan.

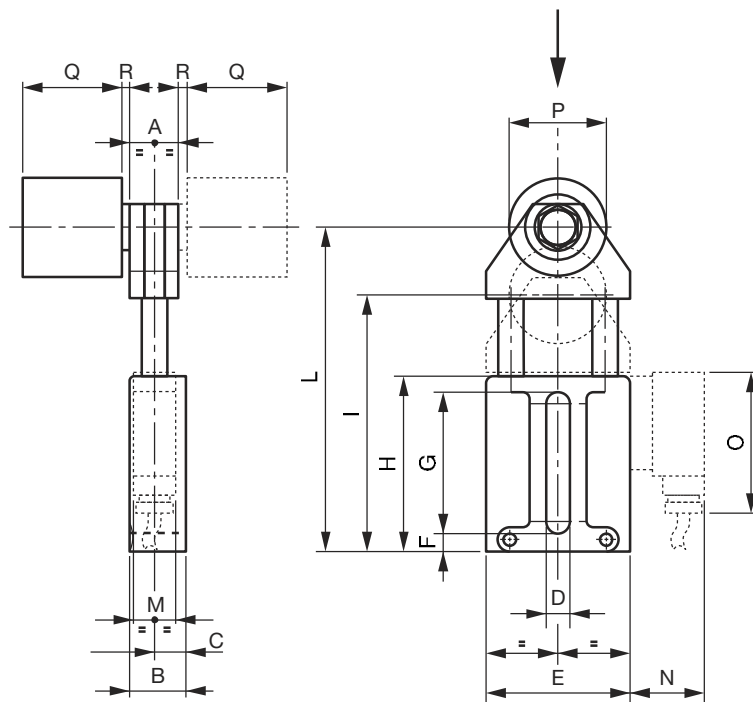

Tyyppi	P [N]		A	B	C	D	E	F	G	H	I	L	M	N	O	P	Q	R
	min.	maks.																
ET1 - PU	130	250	20	23	12,5	11,0	56,2	7	58	74	99	127				50	50	2,5
ET2 - PU	180	420	25	28	15	12,5	70,5	9	70	87	127	163				50	50	2,5
ET3 - PU	300	650	30	33	17,5	14,5	82,0	9	86	104	151	193	21	35	70	50	50	2,5

TYYPPI ETR

Sisältää laakeroidun ketjupyörän.

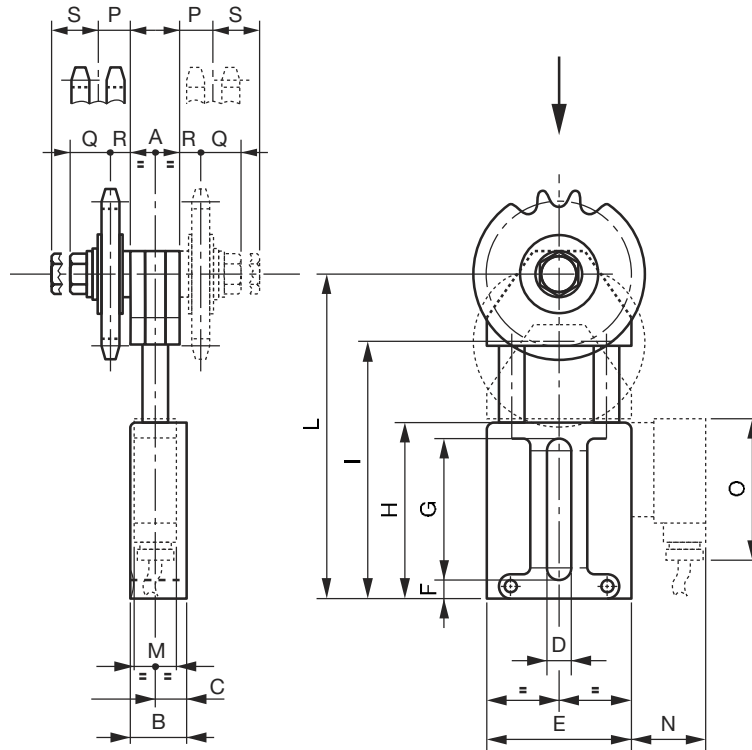
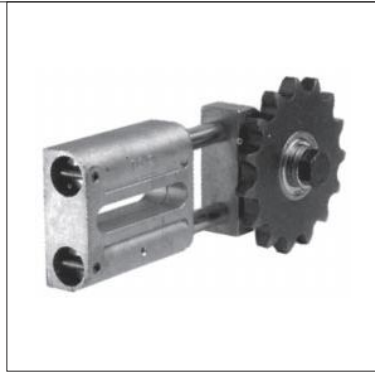

Tyyppi	P [N]		Ketjulle	Z	A	B	C	D	E	F	G	H	I	L	M	N	O	P	Q	R	S
	min.	maks.																			
ETR1 - 3/8"	130	250	3/8" x 7/32"	21	20	23	12,5	11,0	56,2	7	58	74	99	127				11,0	19,7	9,2	18,0
ETR1 - 1/2"	130	250	1/2" x 5/16"	16	20	23	12,5	11,0	56,2	7	58	74	99	127				12,5	19,7	9,2	16,5
ETR2 - 5/8"	180	420	5/8" x 3/8"	17	25	28	15,0	12,5	70,5	9	70	87	127	163				15,3	19,7	9,2	21,8
ETR2 - 3/4"	180	420	3/4" x 7/16"	15	25	28	15,0	12,5	70,5	9	70	87	127	163				17,7	19,7	9,2	19,4
ETR3 - 1"	300	650	1" x 17 mm	12	30	33	17,5	14,5	82	9	86	104	151	193	21	35	70	26,4	19,4	8,9	26,4

TYYPPI DP

Muovirakenne, kulutusta kestäväällä muovielementillä, jolla on pieni liukukittakerroin.

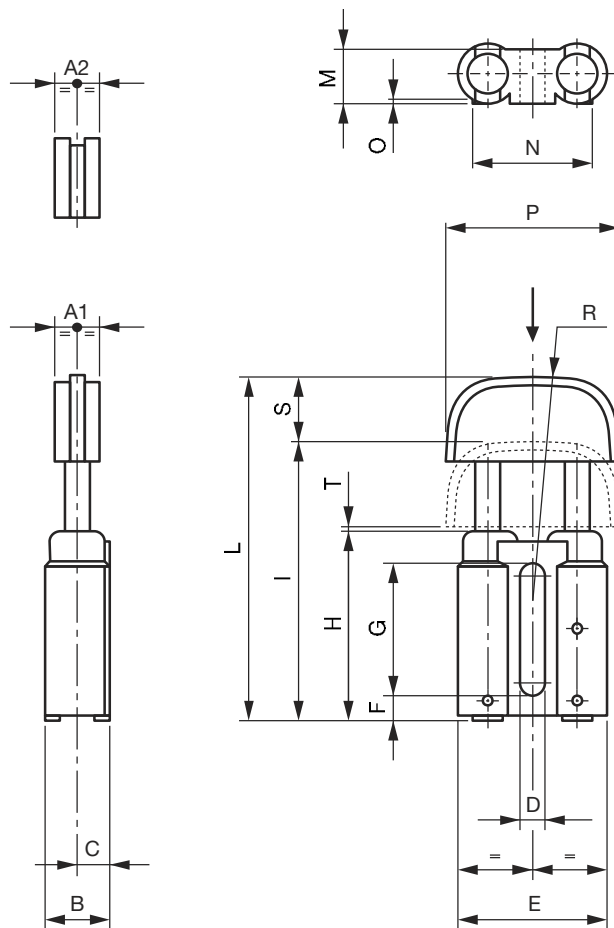

Tyyppi	P [N]		Ketjulle	A1	A2	B	C	D	E	F	G	H	I	L	M	N	Q	P	R	S	T
	min.	maks.																			
*DP - 1 - 3/8"	95	190	3/8" x 7/32"	20	20	25	12,5	9	60	10	53	75	111	139	22	48	1,5	70	100	28	2
*DP - 1 - 1/2"	95	190	1/2" x 5/16"	20	20	25	12,5	9	60	10	53	75	111	139	22	48	1,5	70	100	28	2
*DP - 1 - 5/8"	95	190	5/8" x 3/8"	20	25	25	12,5	9	60	10	53	75	111	139	22	48	1,5	70	100	28	2

* Muovirakenne

TYYPPI TF

- Kulutusta kestävä muovinen liukuosa, jolla on pieni liukukitkerroin (dynaaminen kitkerroin 0,06 kuivalla teräksellä).
- Runko paine valettua kevytmetallia.
- Korkein käyttölämpötila +65°C.

Kiristimet soveltuvat ISO-normin mukaisille ketjulle.

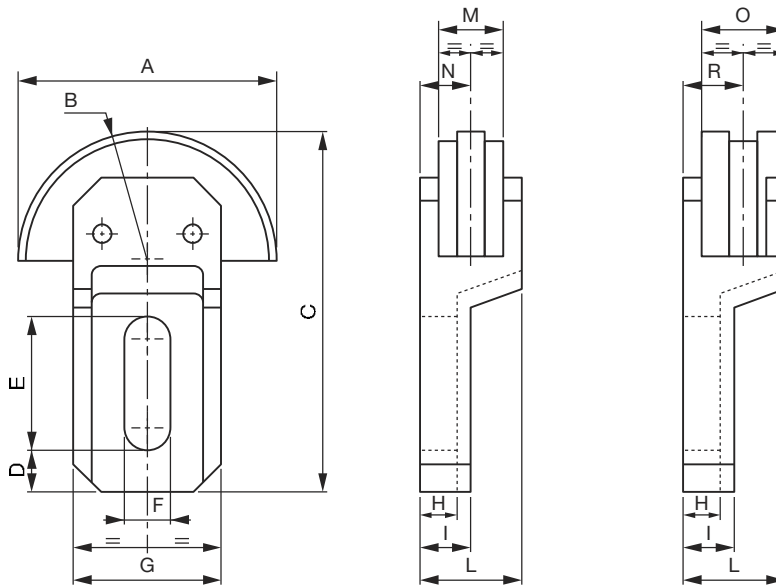
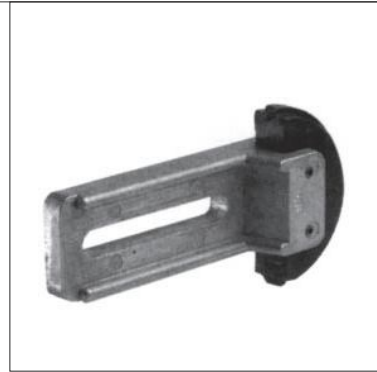

Koko	Ketjulle	A	B	C	D	E	F	G	H	I	L	N	R	A1	A2	A3
													M	O		
TF. 1	3/8"	69	35	138	10	73	10,5	40	10	15	30	15	15,0	20	20	
TF. 1	1/2"	69	35	138	10	73	10,5	40	10	15	30	15	15,25	20	20,5	
TF. 2	5/8"	89	45	164	12	85	12,5	50	12	18	36	18	19,5	22	25	
TF. 2	3/4"	89	45	164	12	85	12,5	50	12	18	36	18	21,75	22	29,5	
TF. 3	1"	109	55	173	13	82	12,5	60	14	20	40	20	30,5	25	46	
TF. 3	1" 1/4	109	55	173	13	82	12,5	60	14	20	40	20		25		
TF. 3	1" 1/2	109	55	173	13	82	12,5	60	14	20	40	20		25		

HUOM! Kiristimet soveltuvat ISO-normitetuille ketjuille.

Tilausesimerkki: Kiristin kaksiriviselle ketjulle, jako 1/2" = TF. 1 - 1/2" A2

A1 = yksirivinen ketju, A2 = kaksirivinen ketju, A3 = kolmirivinen ketju

KAIKKI KETJU- JA HIHNAKÄYTTÖJEN KOMPONENTIT.



Tehonsiirtoketjut

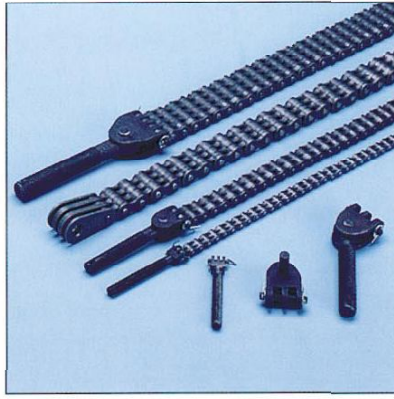

Levykimppuketjut

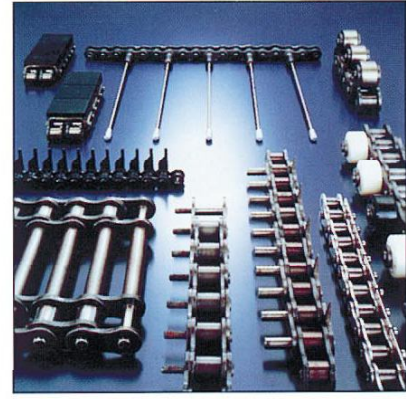

Erikoisketjut



Ketjupyörät



Hammaspyörät ja -tangot



Liukukiskot, ketjun- ja hihnankiristimet

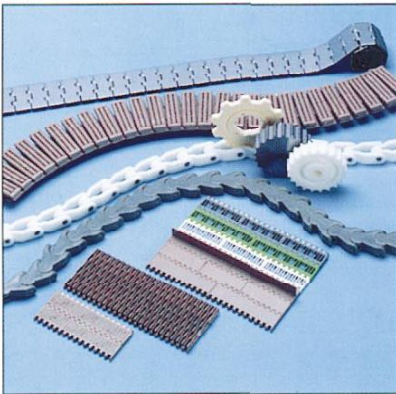

Lamelliketjut ja kuljetinmatot

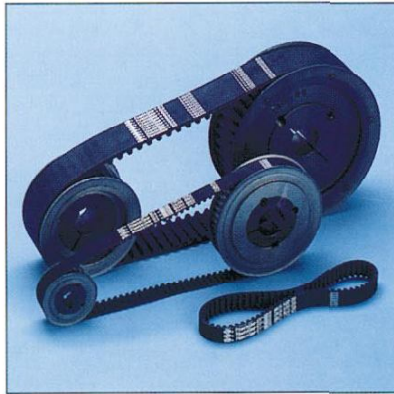

Hammashihnakäytöt

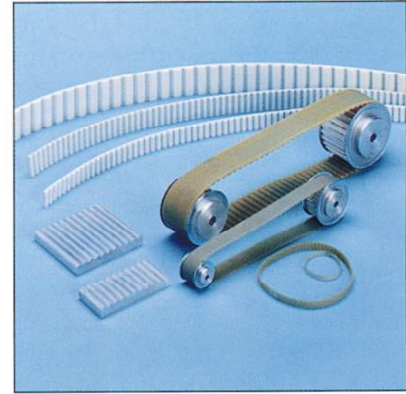

PU-hammashihnakäytöt



Kiilahihnakäytöt

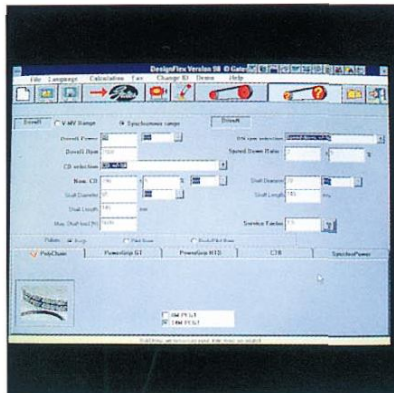

Mitoituspalvelu



Koneistuspalvelu